

G1/4 Mini-Filters

M5-thread inside

(space for a M5-nozzle/orifice/jet)

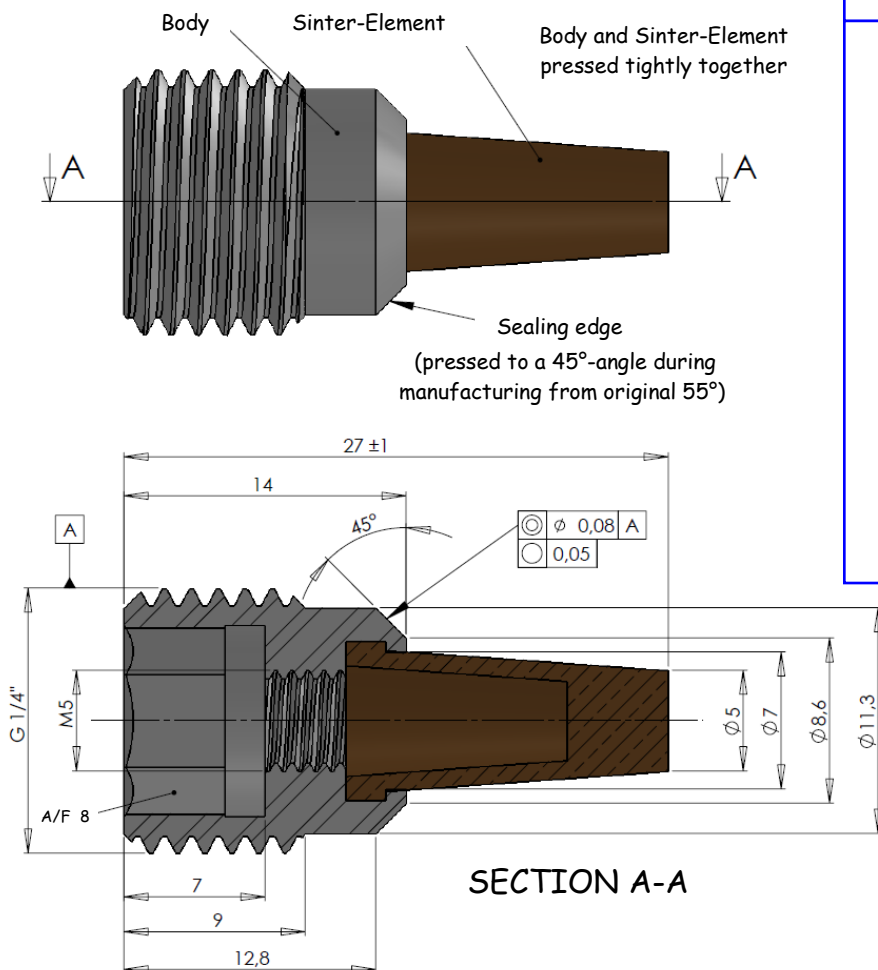
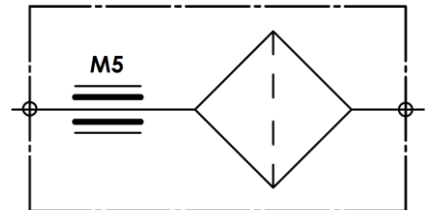

Tightening torque: 25 Nm

Sinter

(Powder-metallurgically manufactured out of bronze, filter grade 4)

Metal powder grain size: 0,250mm - 0,355 mm

Average "hole diameter": 40 µm

Theoretical largest "hole diameter": 75 µm

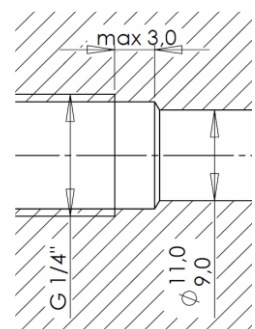

| | | | |
|--|-------------|---------|--|
| <p>Unit Prices:</p> <p>Net, excluding VAT, ex-works Tampere</p> | 1 - 9 pcs | 25 €/pc | <p>Small orders (total value < 150 €): 45 € additional charge (for the work required)</p> |
| | 10 - 29 pcs | 19 €/pc | |
| | 30-99 pcs | 16 €/pc | |
| | 100- pcs | 13 €/pc | |